

VDC Series High-Pressure Type Variable Volume Vane Pump

30 to 120 ℓ /min
14MPa

Features

① Highly efficient and stable high-pressure operation

Innovative pressure control and pressure balance mechanisms combine with an original 3-point ring support system dramatically improves high-pressure operation. The result is outstanding performance at high pressures up to 14MPa.

② Low vibration and noise

A number of innovative new mechanisms are adopted to minimize vibration and noise. In particular, a 3-point support system is used for the control piston and bias pis-

ton to increase ring stability. This minimizes ring vibration and delivers quiet operation.

③ Outstanding response, high-precision operation

An innovative new ring stopper eliminates excessive ring displacement and improves response. The result is high precision operation at all times, including during starts, stops, and load changes.

④ Precise characteristics for a stable discharge rate

A revolutionary new pressure compensator type pressure con-

trol mechanism ensures a highly stable fixed discharge rate, even in the high pressure range.

⑤ High efficiency operation with minimal power loss

New mechanical innovations minimize power loss, especially at full cutoff.

⑥ Simplified maintenance and handling

Pressure adjusting and discharge rate adjusting mechanisms are located on the same side of the pump for simplified maintenance and handling.

Specifications

Model No.	Capacity cm ³ /rev	No-load Discharge Rate (ℓ/min)				Pressure Adjustment Range MPa {kgf/cm ² }	Allowable Peak Pressure MPa {kgf/cm ² }	Revolution Speed min ⁻¹		Weight kg
		1000min ⁻¹	1200min ⁻¹	1500min ⁻¹	1800min ⁻¹			Min.	Max.	
VDC-1A(B)-1A2-20 1A3 1A4 1A5	16.7	16.7	20	25	30	1.5 to 3.5 {15.3 to 35.7} 2 to 7 {20.4 to 71.4} 5 to 10.5 {51 to 107} 7 to 14 {71.4 to 143}	14{143}	800	1800	9.5
						21{214}				
VDC-1A(B)-2A2-20 2A3	22	22	27	33	40	1.5 to 3.5 {15.3 to 35.7} 2 to 7 {20.4 to 71.4}	14{143}	800	1800	9.5
VDC-2A(B)-1A2-20 1A3 1A4 1A5	30	30	36	45	54	1.5 to 3.5 {15.3 to 35.7} 2 to 7 {20.4 to 71.4} 5 to 10.5 {51 to 107} 7 to 14 {71.4 to 143}	14{143}	800	1800	25
						21{214}				
VDC-2A(B)-2A2-20 2A3	39	39	47	58	70	1.5 to 3.5 {15.3 to 35.7} 2 to 7 {20.4 to 71.4}	14{143}	800	1800	25
VDC-3A(B)-1A2-20 1A3 1A4 1A5	67	67	80	100	120	1.5 to 3.5 {15.3 to 35.7} 2 to 7 {20.4 to 71.4} 5 to 10.5 {51 to 107} 7 to 14 {71.4 to 143}	14{143}	800	1800	47 (33)
						21{214}				

Double Pump

Model No.	Vent Side			Shaft Side			Revolution Speed min ⁻¹		Weight kg
	Discharge Rate ℓ/min		Pressure Adjustment Range MPa {kgf/cm ² }	Discharge Rate ℓ/min		Pressure Adjustment Range MPa {kgf/cm ² }	Min.	Max.	
	1800min ⁻¹	1500min ⁻¹		1800min ⁻¹	1500min ⁻¹				
VDC-11A(B)-2A3-2A3-20 VDC-11A(B)-2A3-1A5-20	40	33	2 to 7 {20.4 to 71.4}	40	33	2 to 7 {20.4 to 71.4} 7 to 14 {71.4 to 143}	800	1800	Type A 27 Type B 20
VDC-12A(B)-2A3-2A3-20 VDC-12A(B)-2A3-1A5-20 VDC-12A(B)-1A5-2A3-20 VDC-12A(B)-1A5-1A5-20	40	33	2 to 7 {20.4 to 71.4}	70	58	2 to 7 {20.4 to 71.4} 7 to 14 {71.4 to 143}	800	1800	Type A 42 Type B 35
	30	25	7 to 14 {71.4 to 143}	70	58	2 to 7 {20.4 to 71.4} 7 to 14 {71.4 to 143}			
VDC-22A(B)-2A3-2A3-20 VDC-22A(B)-2A3-1A5-20	70	58	2 to 7 {20.4 to 71.4}	70	58	2 to 7 {20.4 to 71.4} 7 to 14 {71.4 to 143}	800	1800	Type A 62 Type B 50
VDC-13A(B)-2A3-1A3-20 VDC-13A(B)-2A3-1A5-20 VDC-13A(B)-1A5-1A3-20 VDC-13A(B)-1A5-1A5-20	40	33	2 to 7 {20.4 to 71.4}	120	100	2 to 7 {20.4 to 71.4} 7 to 14 {71.4 to 143}	800	1800	Type A 62 Type B 48
	30	25	7 to 14 {71.4 to 143}			2 to 7 {20.4 to 71.4} 7 to 14 {71.4 to 143}			

Note) 1. VDC-3A, VDC-11A, VDC-12A and VDC-13A are foot mounting types, and come with foot mountings.
2. VDC-1A and VDC-2A are sub plate types. Sub plates are not included.

● Handling

- ① **Rotation Direction** The direction of rotation is always clockwise (rightward) when viewed from the shaft side.
- ② **Drain** Drain piping must be direct piping up to a point that is below the tank fluid level, and piping should comply with the conditions shown in the table below to ensure that back pressure due to pipe resistance does not exceed 0.1MPa. When using a pump that has drain ports at two locations, use the drain port that is higher after the pump is installed. In the case of a double pump, run separate pipes from both the shaft side and the head side drains directly connect to the tank, so the drain pipe is below the surface of the oil.

Model No. Item	VDC-1	VDC-2	VDC-3
Pipe Joint Size	At least 1/4"	At least 1/4"	At least 3/8"
Pipe I.D.	At least φ7.6	At least φ7.6	At least φ9.6
Pipe Length	1m or less	1m or less	1m or less

- ③ **Discharge Volume Adjustment**
The discharge flow rate is decreased by clockwise (rightward) rotation of the discharge rate adjusting screw, and increased by counterclockwise (leftward) rotation. Loosen the lock nut before making adjustments. After adjustment is complete, re-tighten the lock nut. The graph below provides general guidelines for the relationship between the rotation angle of the flow rate adjusting screw and the no-load discharge rate.

However: $Q = q \times N \times 10^{-3}$
 Q : No-load Discharge Rate ℓ / min
 q : Volume cm^3 / rev
 N : Revolution Speed min^{-1}

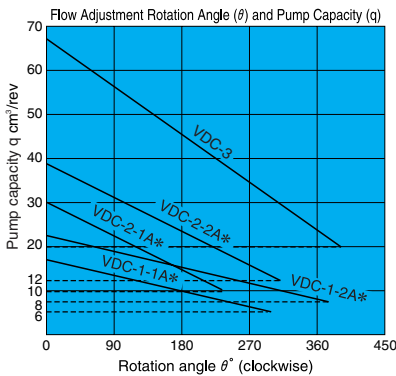

Note)
The values indicated above are at maximum pump discharge volume with the flow volume adjusting screw at the 0° position. The broken line shows the flow volume adjustment range lower limit value.

- ④ **Pressure Adjustment** Pressure is increased by clockwise (rightward) rotation of the discharge rate adjusting screw, and decreased by counterclockwise (leftward) rotation. Loosen the lock nut before making adjustments. After adjustment is complete, re-tighten the lock nut.

- ⑤ **Factory Default P-Q Settings (Standard Model)**
 - Flow Rate Setting = Maximum flow rate for model as indicated in the catalog
 - Pressure Setting = Pressure shown in table below

- ⑥ **Thrust Screw and Stopper**
The thrust screw and stopper are precision adjusted at the factory during assembly. Never touch them. See callouts 15/43 and 15/38 in the VDC-1A and 2A/3A cross-section diagrams on pages B-33 and B-34.

- ⑦ **An unload circuit is required** when the motor is started under condition $\lambda - \Delta$. Contact your agent about the unload circuit.

- ⑧ **Initial Operation** Before operating the pump for the first time, put the pump discharge side into the no-load state and then repeatedly start and stop the motor to bleed all air from inside the pump and the suction piping. After confirming that the pump is discharging oil, continue the no-load operation for at least 10 minutes to discharge all the air from the circuit. Provide an air bleed valve in circuits where it is difficult to bleed air before startup.

- ⑨ **Sub Plate**
Use the table below for to specify a sub plate type when one is required.

Factory Default Pressure Settings MPa(kgf/cm ²)
2 : 3.5 {35.7}
3 : 3 {30.6}
4 : 5 {51}
5 : 7 {71.4}

Sub Plate Number

Pump Model No.	Sub Plate Number	Motor (kW)
VDC-1A-1A*-20	MVD-1-115-10	0.75 to 1.5
	MVD-1-135-10	2.2 to 3.7
VDC-1A-2A*-20	MVD-1-115Y-10	0.75 to 1.5
	MVD-1-135Y-10	2.2 to 3.7
VDC-2A-*A*-20	MVD-2-135-10	2.2 to 3.7
	MVD-2-160-10	5.5
VDC-2A-2A*-20	MVD-2-160Z-10	5.5

Note) See pages B-17 and B-18 for detailed dimensions.

⑩ **Foot Mounting**

For a double pump with VDC-3 foot mounting, the foot mounting kit and pump are sold as a set. When only the mounting feet are required, pump mounting bolts, washers and other parts are sold together as the Foot Mounting Kit. See page B-36 for detailed dimensions.

- ⑪ For the hydraulic operating fluid, use type ISO VG32 or equivalent (viscosity index of at least 90) for pressures of 7MPa or lower, and type ISO VG68 or equivalent (viscosity index of at least 90) for pressures greater than 7MPa.

- ⑫ The operating temperature range is 15 to 60°C. When the oil temperature at startup is 15°C or less, perform a warm-up operation at low pressure until the oil temperature reaches 15°C. Use the pump in an area where the temperature is within the range of 0 to 60°C.

- ⑬ Suction pressure is -0.03 to +0.03MPa (-0.3 to +0.3kgf/cm²), and the suction port flow rate should be no greater than 2m/sec.

- ⑭ **Avoid pulley, gear, and other drive systems** that impart a radial or thrust load on the end of the pump shaft.

Mount the pump so its pump shaft is oriented horizontally.

- ⑮ Provide a suction strainer with a filtering grade of about 100μm (150 mesh). For the return line to the tank, use a 25μm line filter.

- ⑯ **Manage hydraulic operating fluid** so contamination is maintained at class NAS10 or lower. Take care to avoid contamination with water and other foreign matter, and watch out for discoloration. Whitish fluid indicates that air has contaminated the fluid, and brownish fluid indicates the fluid is dirty.

- ⑰ Contact your agent about using water- and glycol-based hydraulic operating fluids.

- ⑱ At startup, repeat the inching operation (start-stop) to bleed air from the pump and pipes.

(Continued on following page)

19 Equip an air bleed valve in circuits where it is difficult to bleed air before startup. See page C-13 for more information.

20 To ensure proper lubrication of the pump's rubbing surfaces, supply oil to the interior of the pump before starting operation.

21 When centering the pump shaft, eccentricity with the motor shaft should be no greater than 0.05mm. Use a pump mounting base of sufficient rigidity.

The angle error should be no greater than 1°.

Understanding Model Numbers

Single Pump

VDC-2 A-1 A 2-20

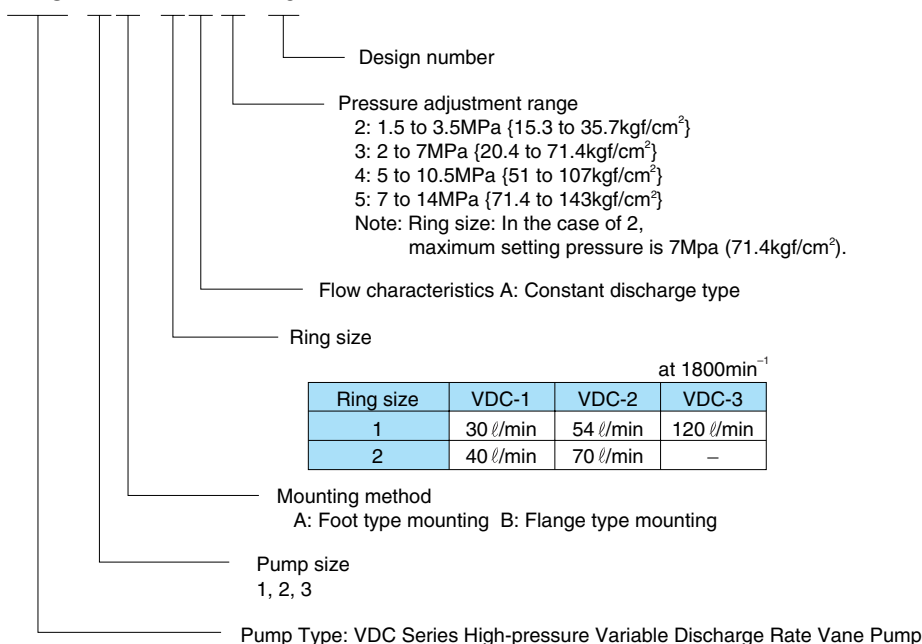

Double Pump

VDC-1 2 A-1 A 5-2 A 3-20

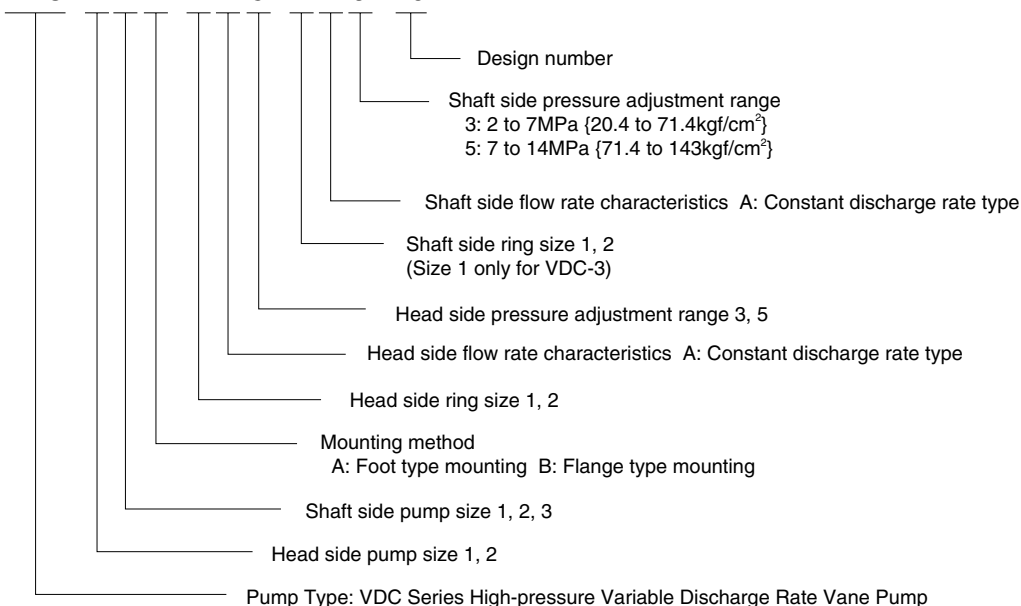

Installation Dimension Drawings

Single Pump
VDC-1A-*A*-20

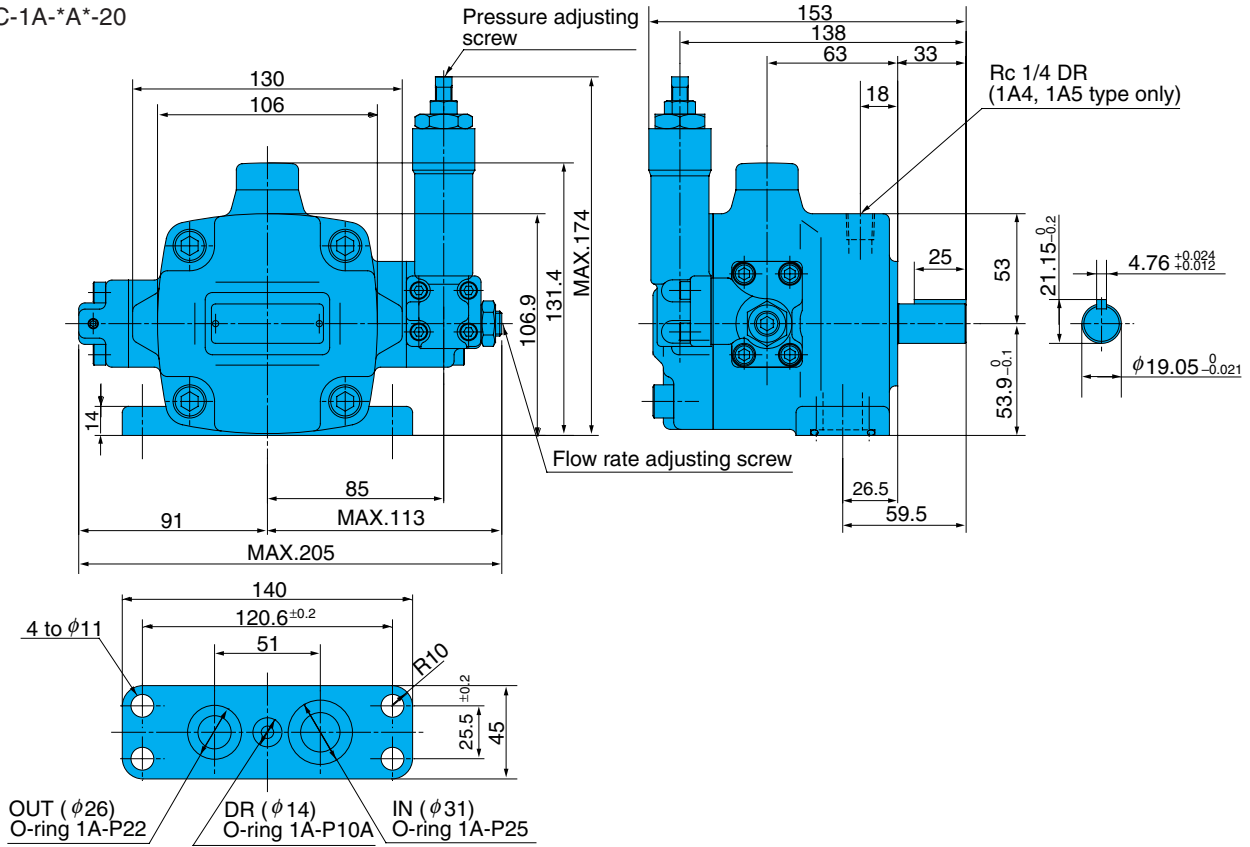

VDC-1B-*A*-20

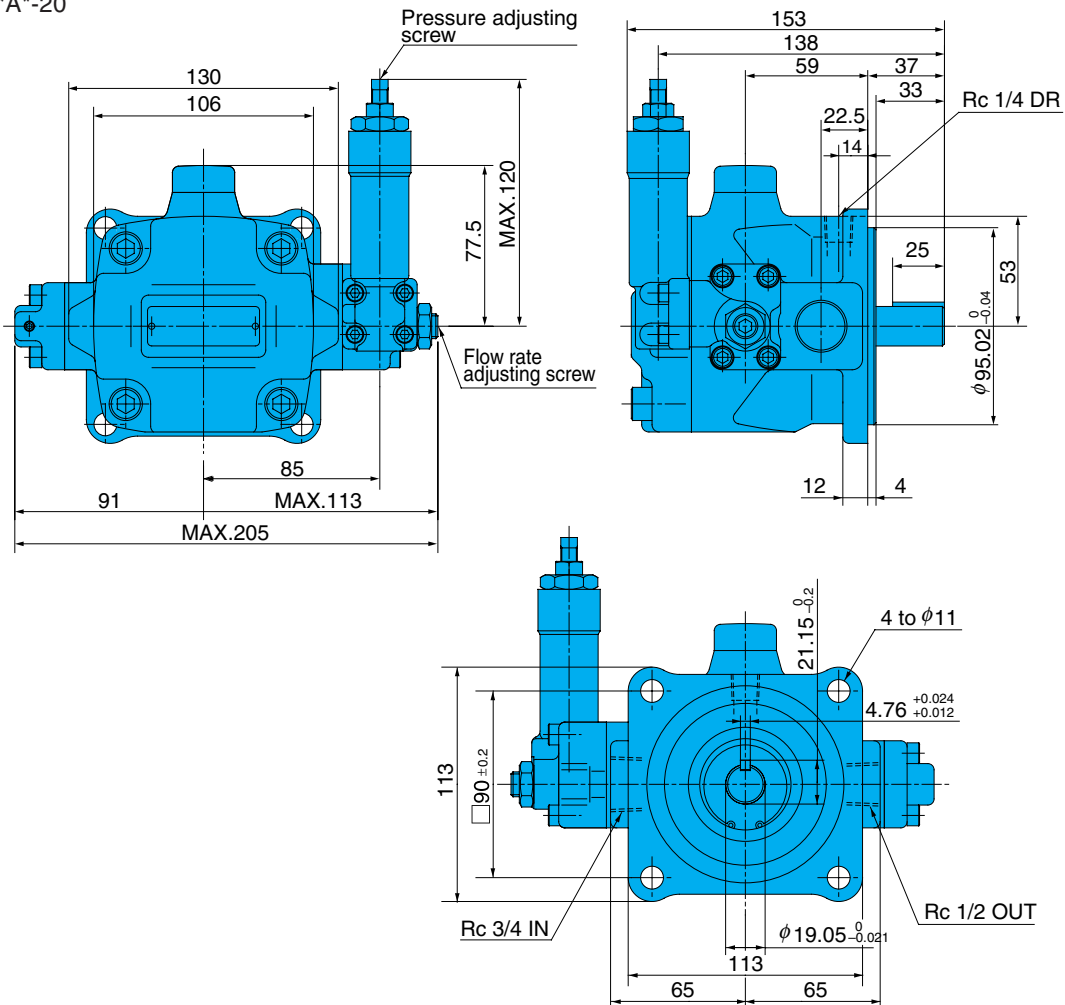

VDC-2A-*A*-20

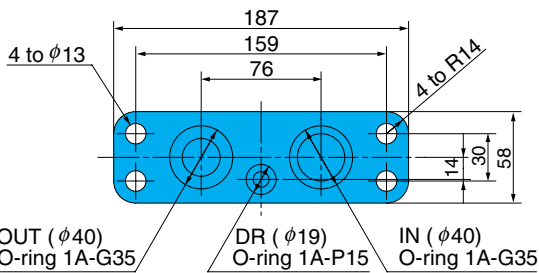
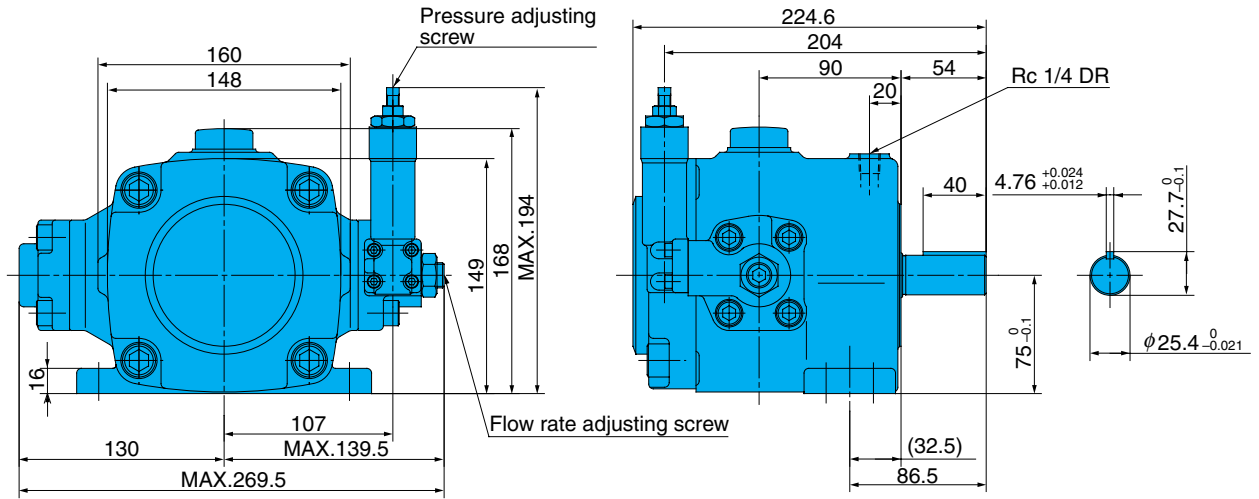

Note)
O-ring 1A-** refers to JIS B2401-1A-**.

VDC-2B-*A*-20

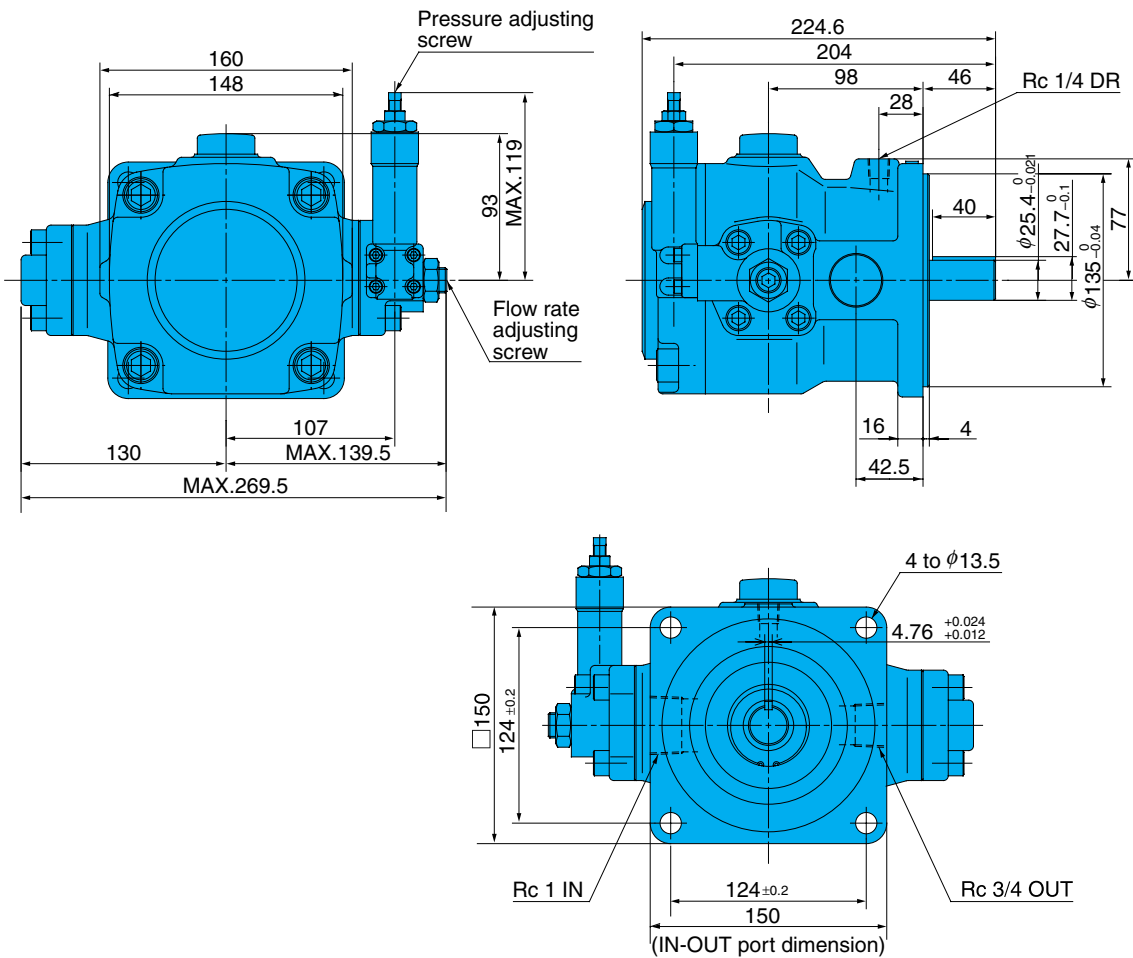

VDC-3A-1A*-20

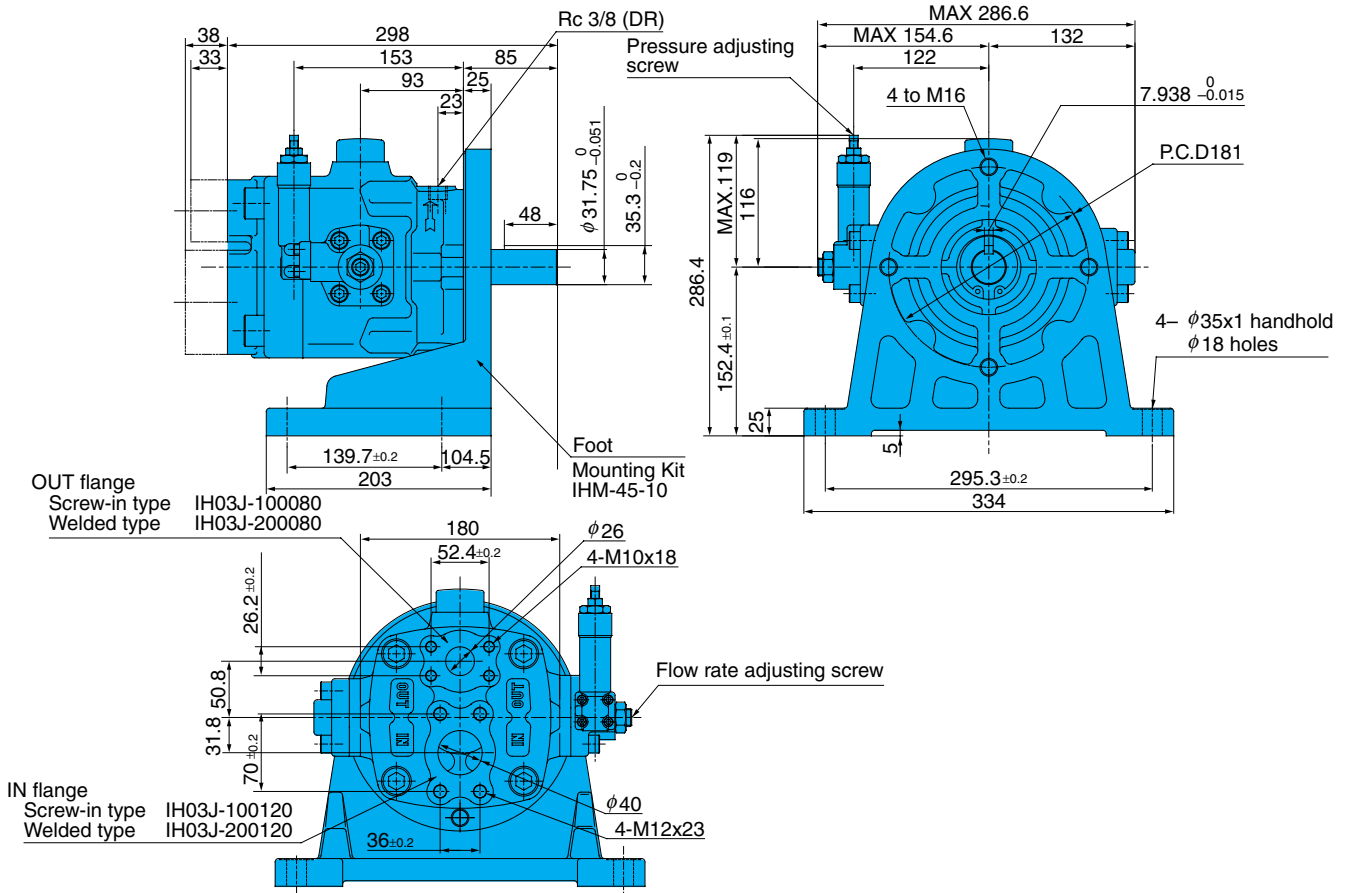

VDC-3B-1A*-20

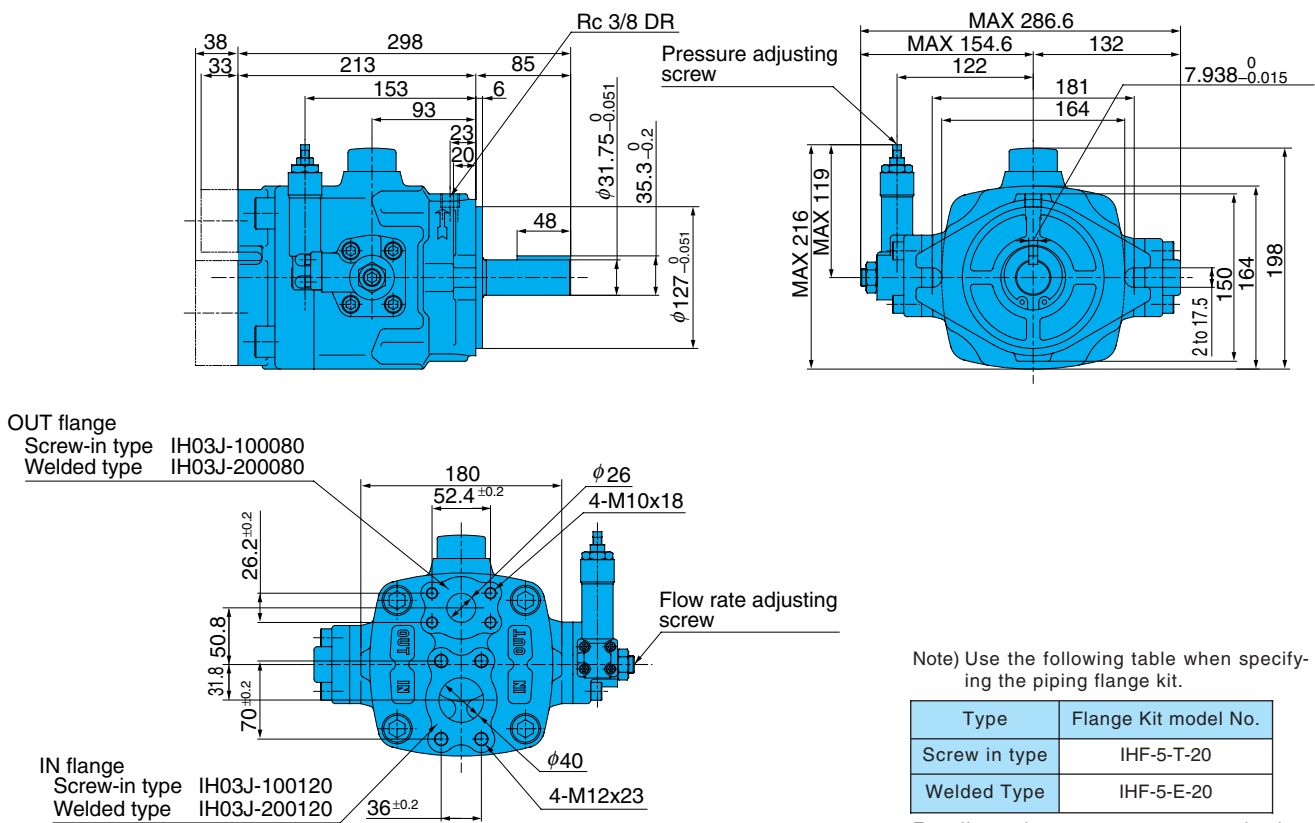

Note) Use the following table when specifying the piping flange kit.

Type	Flange Kit model No.
Screw in type	IHF-5-T-20
Welded Type	IHF-5-E-20

For dimensions, components, and other details, see the IP pump piping flange kits on pages C-10 and C-11.

Double Pump
VDC-11B-*A*-*A*-20

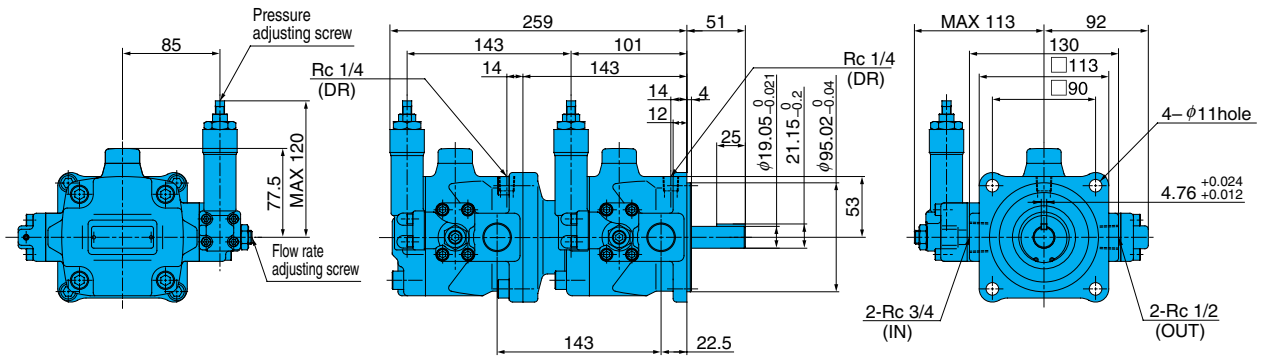

VDC-12B-*A*-*A*-20

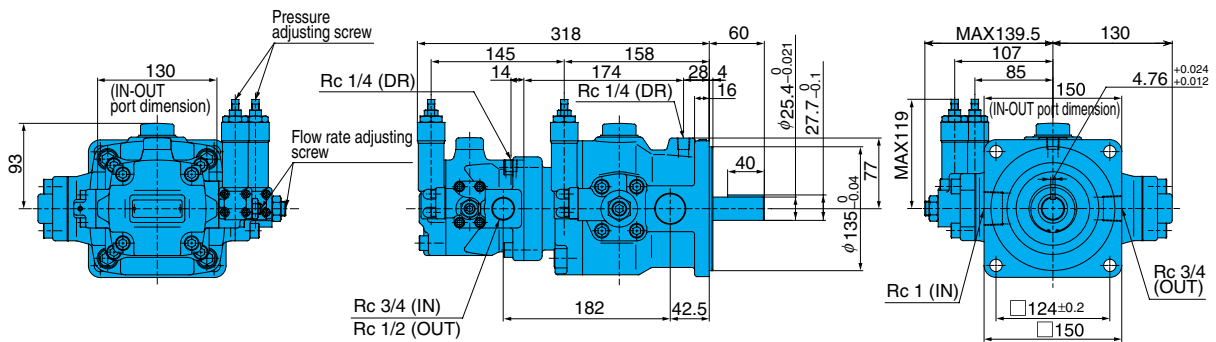

VDC-22B-*A*-*A*-20

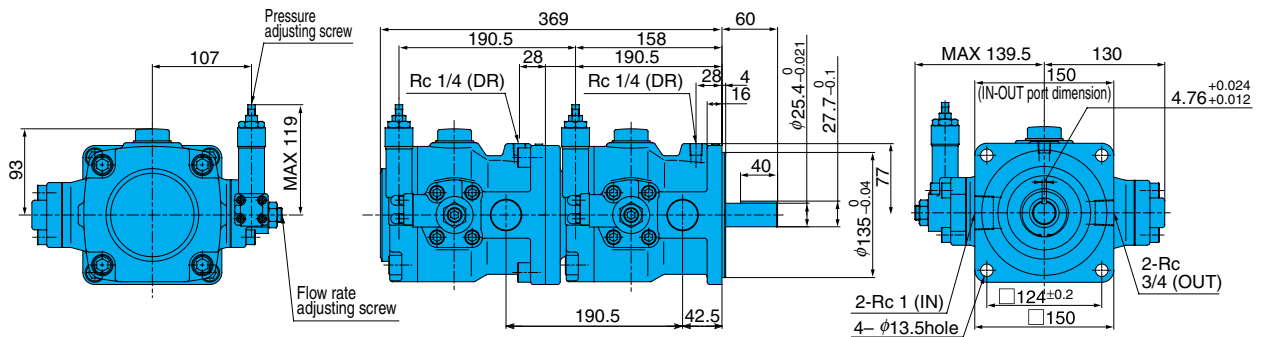

VDC-13B-*A*-*A*-20

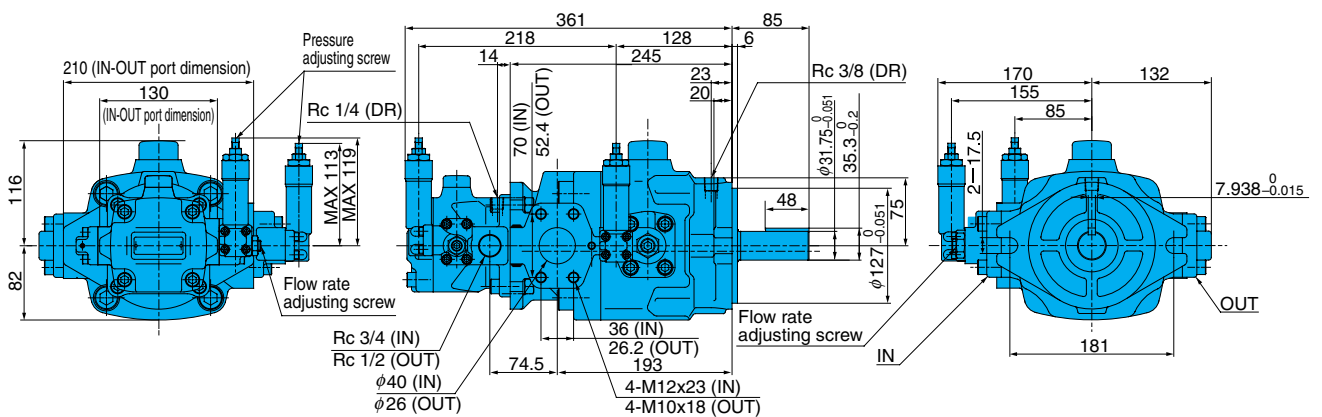

Note) 1. VDC-**A has the foot mounting kit shown on page B-36 installed.
2. Rc-* previously was PT*.

Performance Curves

Typical characteristics at hydraulic operating fluid kinematic viscosity of 32 mm²/s

VDC-1A(B)-1A3-20

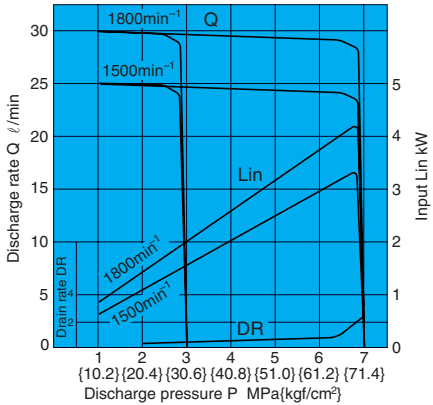

VDC-1A(B)-2A3-20

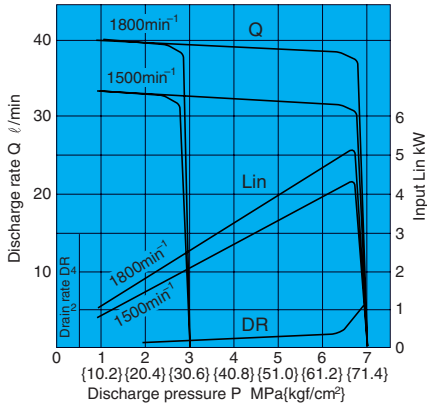

VDC-2A(B)-2A3-20

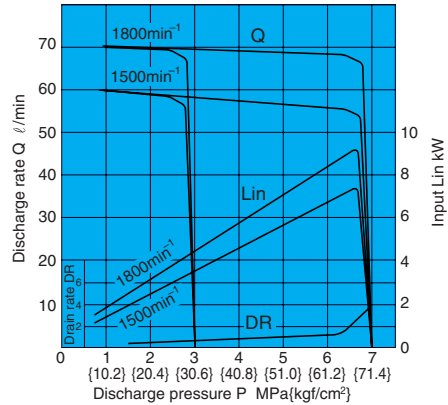

VDC-2A(B)-1A3-20

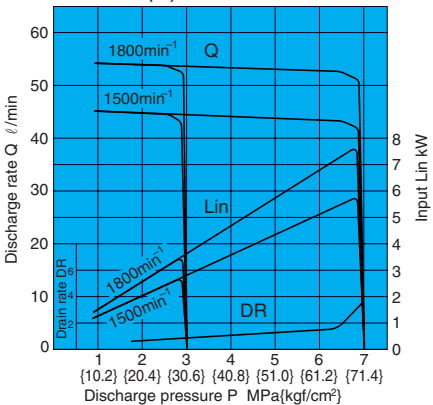

VDC-3A(B)-1A3-20

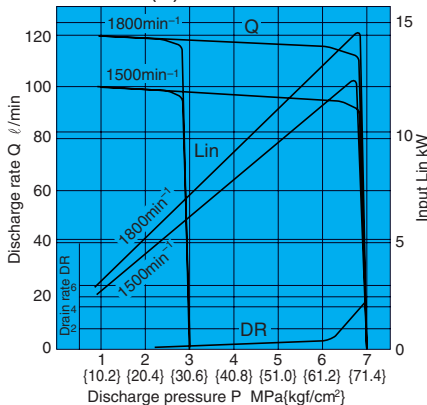

VDC-1A(B)-1A5-20

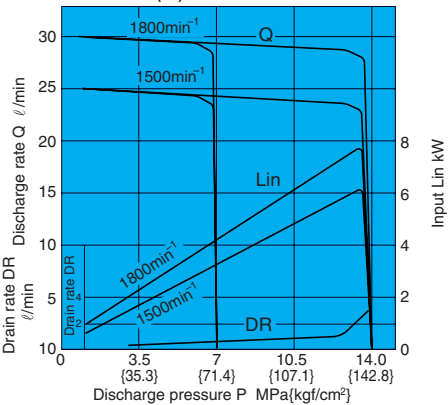

VDC-2A(B)-1A5-20

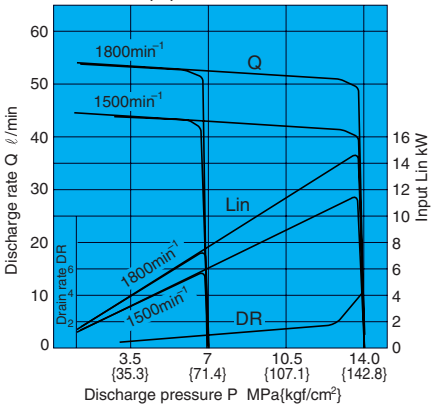

VDC-3A(B)-1A5-20

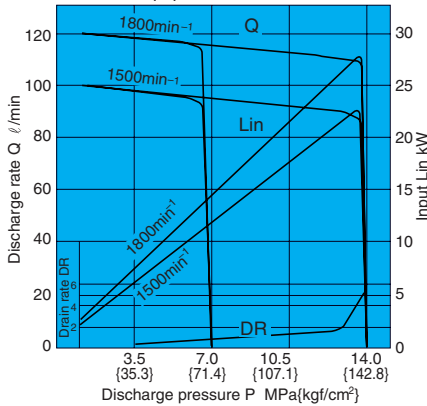

Use the formula below to calculate a pump's required drive force.

$$H = \frac{PQ}{60} + L$$

H : Input (kW)
P : Pressure MPa
Q : Flow rate ℓ/min
L : Power loss kW

Power loss

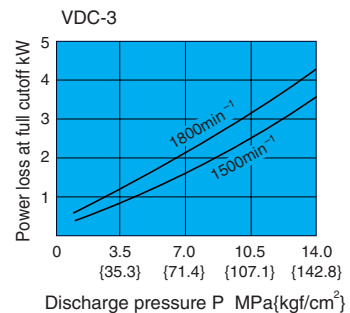
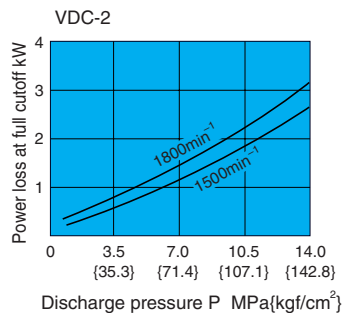
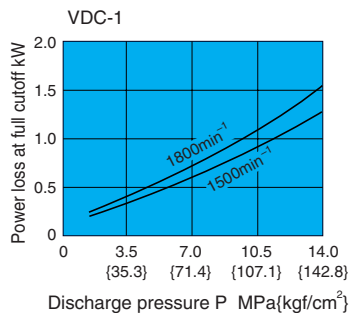

Noise Characteristics

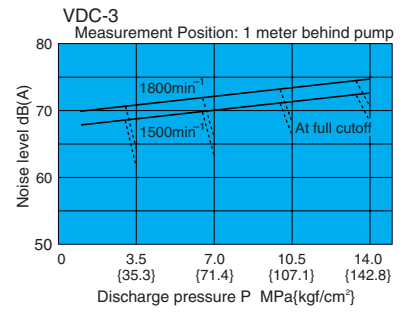
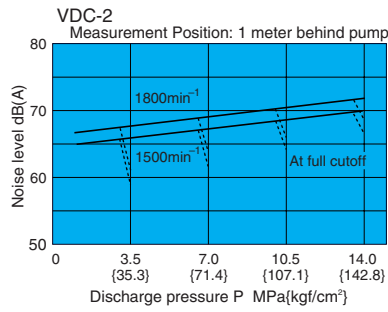
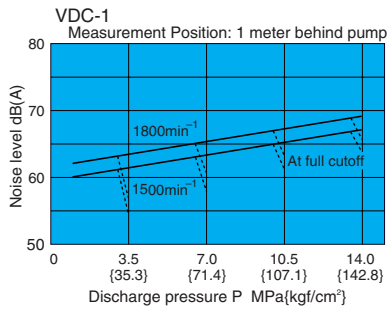

Cross-sectional Drawing

VDC-1A-*A*-20

VDC-2A-*A*-20

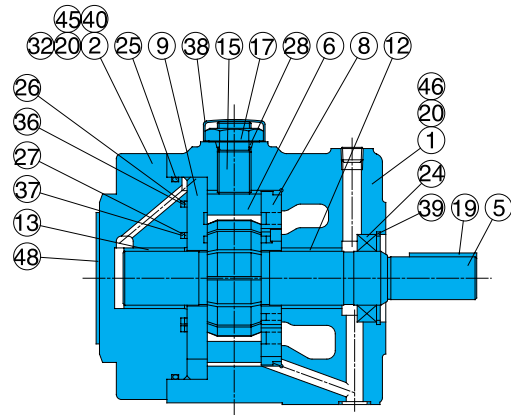
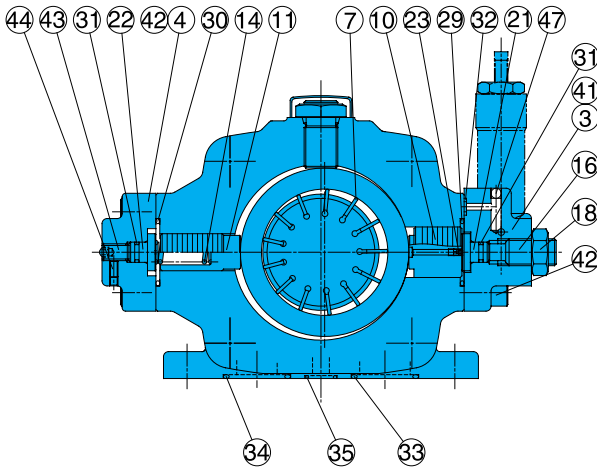

Seal Component Table (VDC-1*, VDC-2*)

Part No.	Applicable Pump Model No.	VDC-1A-*A*-20		VDC-2A-*A*-20	
	Seal Kit Number	VCBS-101A00		VCBS-102A00	
	Part Name	Part Number	Q'ty	Part Number	Q'ty
24	Oil seal	TCV-224211	1	TCN-325211	1
25	O-ring	S85(NOK)	1	1A-G115	1
26	O-ring	AS568-034	1	AS568-150	1
27	O-ring	AS568-026	1	AS568-134	1
28	O-ring	1A-P14	1	1A-P18	1
29	O-ring	1A-P22	1	1A-G35	1
30	O-ring	1A-P20	1	1A-G35	1
31	O-ring	1A-P5	2	1A-P9	2
32	O-ring	1A-P6	4	1A-P7	4
33	O-ring	1A-P25	1	1A-G35	1
34	O-ring	1A-P22	1	1A-G35	1
35	O-ring	1A-P10A	1	1A-P15	1
36	Backup ring	VCB34-101000	1	VCB34-102000	1
37	Backup ring	VCB34-201000	1	VCB34-202000	1
57	O-ring	1A-P14	1	1A-P14	1
58	O-ring	1B-P6(Hs90)	3	1B-P6(Hs90)	3

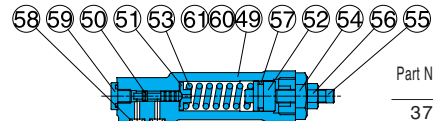

Part No.	Part Name	Part No.	Part Name
1	Body (1)	19	Key
2	Body (2)	20	Pin
3	Cover (1)	21	Holder
4	Cover (2)	22	Holder
5	Shaft	23	Orifice
6	Ring	24	Oil seal
7	Vane	25	O-ring
8	Plate (S)	26	O-ring
9	Plate (H)	27	O-ring
10	Piston (1)	28	O-ring
11	Piston (2)	29	O-ring
12	Bearing	30	O-ring
13	Bearing	31	O-ring
14	Spring	32	O-ring
15	Thrust screw	33	O-ring
16	Screw	34	O-ring
17	Nut	35	O-ring
18	Nut	36	Backup ring
		37	Backup ring
		38	Cap
		39	Snap ring
		40	Screw
		41	Screw
		42	Screw
		43	Screw (stopper)
		44	Screw
		45	Plug
		46	Plug
		47	Pole
		48	Nameplate
		49	Valve body
		50	Spool
		51	Holder
		52	Plunger
		53	Spring
		54	Retainer
		55	Screw
		56	Nut
		57	O-ring
		58	O-ring
		59	Plug
		60	Plug
		61	Screw

Note) 1. Oil seals are manufactured by Nippon Oil Seal Industry Co. Ltd. (NOK).
 2. O-ring 1A-** refers to JIS B2401-1A-**.
 3. For VDR-*B*-20, the seal kit number becomes VDBS-10*B00, without the 33, 24, and 35 O-rings.

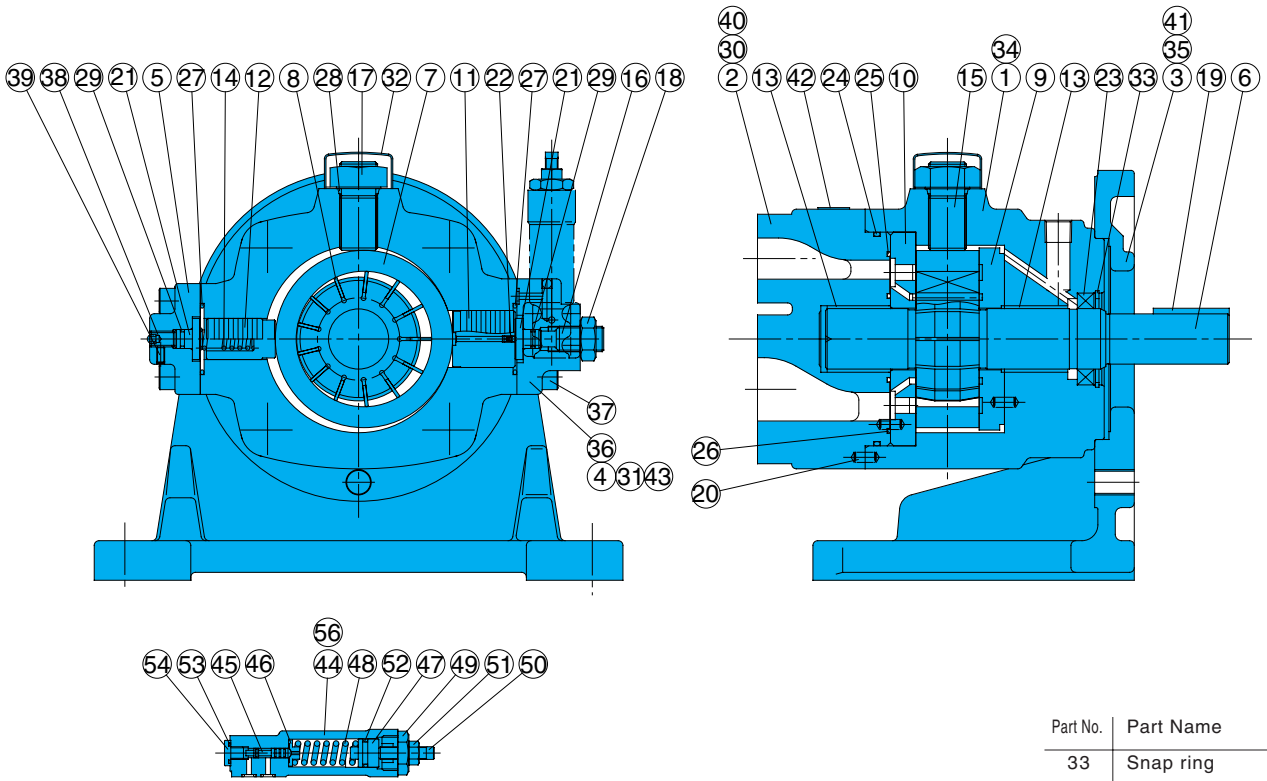

Seal Component Table (VDC-3*)

Part No.	Applicable Pump Model No.	VDC-3A(B)*-20	
	Seal Kit Number	VCBS-103B00	
	Part Name	Part Number	Q'ty
23	Oil seal	TCN-385811	1
24	O-ring	1A-G130	1
25	O-ring	AS568-154(Hs90)	1
26	O-ring	AS568-151(Hs90)	1
27	O-ring	1A-G40	2
28	O-ring	1A-P22	1
29	O-ring	1A-P9	2
30	O-ring	1A-P7	2
31	O-ring	1A-P7	2
52	O-ring	1A-P14	1
53	O-ring	1B-P6(Hs90)	3

Note) 1. Oil seals are manufactured by Nippon Oil Seal Industry Co. Ltd. (NOK).
2. O-ring 1A-** refers to JIS B2401-1A-**.

Part No.	Part Name	Part No.	Part Name
1	Body (1)	17	Nut
2	Body (2)	18	Nut
3	Mounting	19	Key
4	Cover (1)	20	Pin
5	Cover (2)	21	Holder
6	Shaft	22	Orifice
7	Ring	23	Oil seal
8	Vane	24	O-ring
9	Plate (S)	25	O-ring
10	Plate (H)	26	O-ring
11	Piston (1)	27	O-ring
12	Piston (2)	28	O-ring
13	Bearing	29	O-ring
14	Spring	30	O-ring
15	Thrust screw	31	O-ring
16	Screw	32	Cap
		33	Snap ring
		34	Screw
		35	Screw
		36	Screw
		37	Screw
		38	Screw (stopper)
		39	Screw
		40	Plug
		41	Washer
		42	Nameplate
		43	Pole
		44	Valve body
		45	Spool
		46	Holder
		47	Plunger
		48	Spring
		49	Retainer
		50	Screw
		51	Nut
		52	O-ring
		53	O-ring
		54	Plug
		55	Plug
		56	Screw

VDC Series
Double Pump

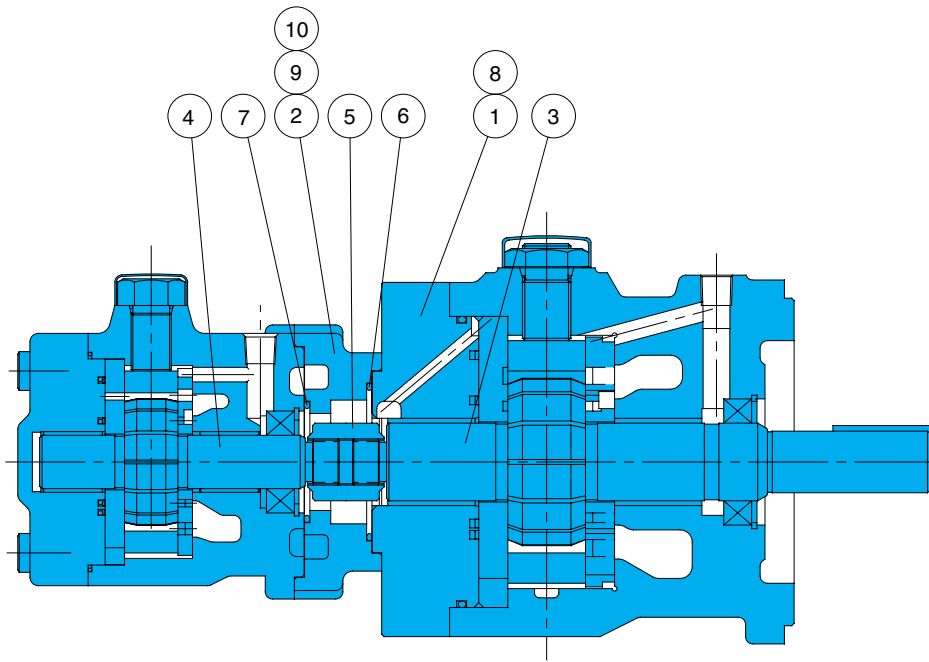

Part No.	Part Name
1	Body (2)
2	Body (3)
3	Shaft (S)
4	Shaft (H)
5	Joint
6	O-ring
7	O-ring
8	Screw
9	Screw
10	Screw

Note)
In the case of a double pump, use single pump parts in addition to the 10 parts listed above.

List of Sealing Parts

Part No.	Part Name	VDC-11A-*-*-20		VDC-12A-*-*-20		VDC-22A-*-*-20		VDC-13A-*-*-20	
		Part Number	Q'ty	Part Number	Q'ty	Part Number	Q'ty	Part Number	Q'ty
6	O-ring	—		1A-G60	1	1A-G60	1	—	
7	O-ring	1A-G85	1	1A-G45	1	1A-G60	1	1A-G85	1

Note)
1. See the description of the single pump for seal parts that are not included in the list.
2. O-ring 1A-** refers to JIS B2401-1A-**.

Foot Mounting Installation Measurement Chart

For VDC-11A and VDC-*2A

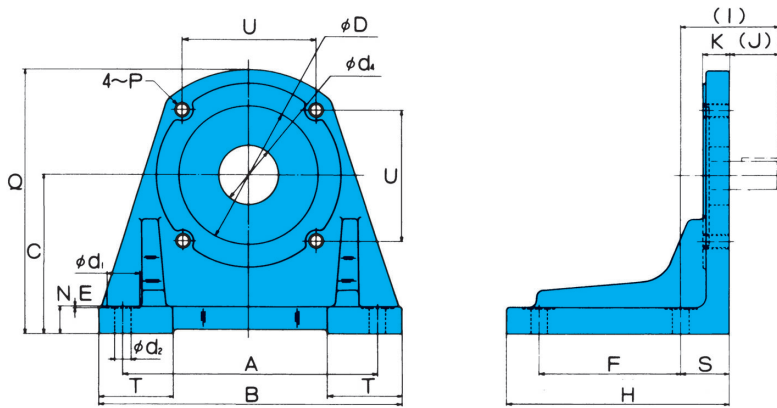

For VDC-3A and VDC-13A

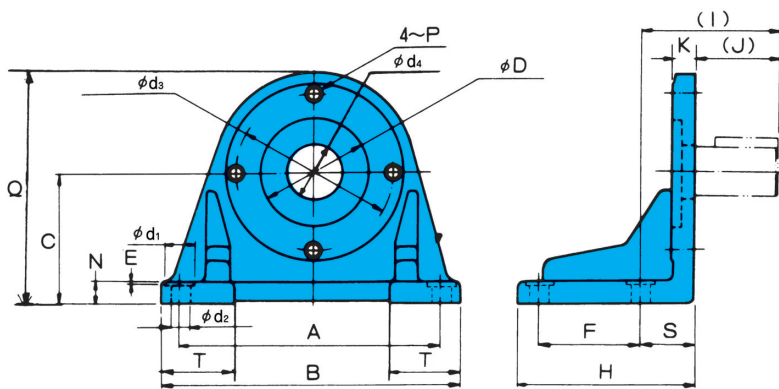

Foot Mounting Kit Model No.	Applicable Pump Model No.	Accessories				Dimensions (mm)					
		Bolt	Q'ty	Washer	Q'ty	A	B	C	E	F	H
VCM-11-20	VDC-11	TH-10 × 30	4	WS-B-10	4	171.45	204	107.95	1	95.25	150
VCM-22-20	VDC-12 VDC-22	TH-12 × 35	4	WS-B-12	4	235	267	139.7	1	127	193
IHM-45-10	VDC-3 VDC-13	TB-16 × 40	2	WP-16	2	295.3	334	152.4	1	139.7	203

Foot Mounting Kit Model No.	Dimensions (mm)														Weight kg
	I	(J)	K	N	P	Q	S	T	U	φ D	φ d ₁	φ d ₂	φ d ₃	φ d ₄	
VCM-11-20	66.5	33	18	18	M10	180	32.5	50	90	95.02	22	11	—	40	6.5
VCM-22-20	84.5	40	20	20	M12	232	44.5	57.5	124	135	22	14	—	40	12.0
IHM-45-10	104.5	60	25	25	M16	259	44.5	61	—	127	35	18	181	86	13.5